

104

Batch Ice Cream Freezer

Features

Serve homemade, low or medium overrun ice cream, gelato, sorbet or Italian ice. Fruits, candies and nuts can be folded in as product is being drawn into your container. Product may be ejected at temperatures low enough for serving, depending on mix formulation, flavorings and overrun desired.

Freezing Cylinder

One, 3 quart (2.9 liter). Pre-charge of liquid mix determines overrun.

Automatic Timer Control

Finished product quality is automatically controlled by setting the time required for the recipe. A buzzer will sound to remind the operator to eject the finished product.

Funnel

Liquid mix and flavorings are poured into the top, using the convenient funnel provided.



Standard 6

LISTED
SA2650Selected 50
Hz. Models

104 Batch Ice Cream Freezer

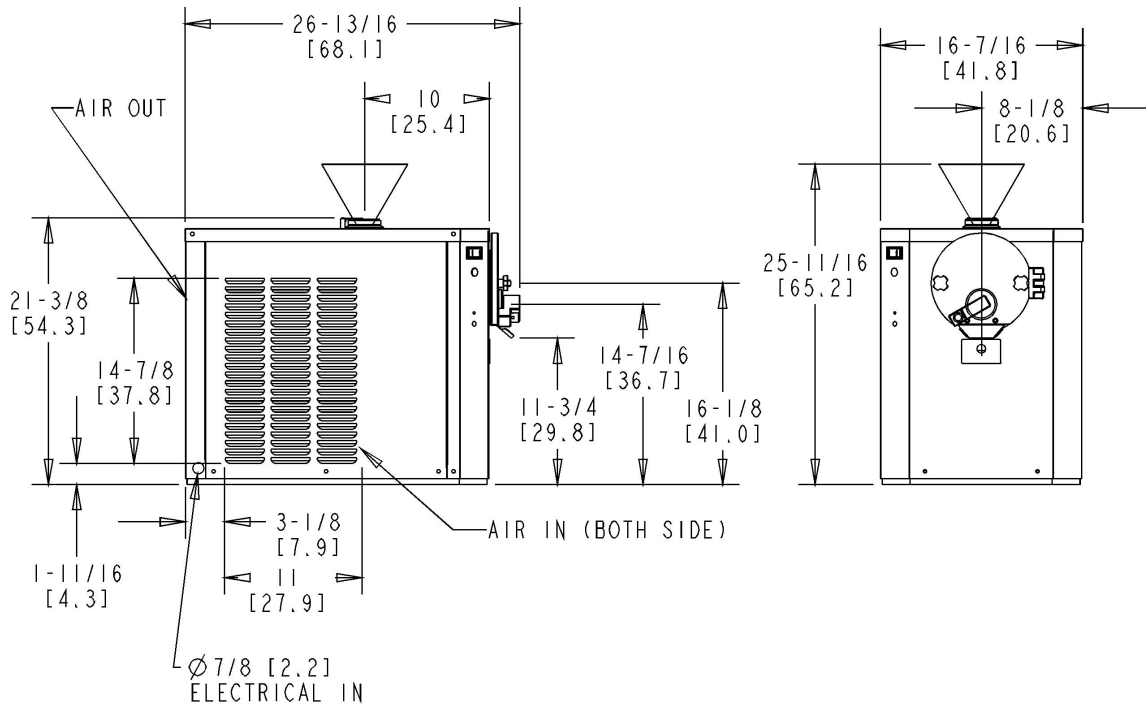

FIGURES IN PARENTHESES
INDICATE CENTIMETERS

Weights	lbs.	kgs.
Net	165	74.9
Crated	199	90.3
	cu. ft.	cu. m.
Volume	17.3	0.49

Dimensions	in.	mm.
Width	16-7/16	418
Depth	26-13/16	681
Height	21-3/8	542
Counter Clearance	---	---

*Designed to rest on a plastic pad directly on counter top.

Electrical	Maximum Fuse Size	Minimum Circuit Ampacity	Poles (P) Wires (W)
115/60/1 Air	35	29	2P 3W
208-230/60/1 Air	15	15	2P 3W
220-240/50/1 Air	15	12	2P 3W

This unit may be manufactured in other electrical characteristics. Refer to the local Taylor Distributor for availability.
(For exact electrical information, always refer to the data label of the unit.)

Bidding Specs

Electrical: Volt _____ Hz _____ ph _____

Neutral: Yes No | Cooling: Air Water NA

Options: _____

Specifications

Electrical

One dedicated electrical connection is required. See the Electrical chart for the proper electrical requirements. Manufactured to be permanently connected. Consult your local Taylor distributor for cord & receptacle specifications as local codes allow.

Beater Motor

One, 1.0 HP.

Refrigeration System

One, approximately 2,500 BTU/hr. R404A.
(BTUs may vary depending on compressor used.)

Air Cooled

Minimum clearance: 6" (152 mm) around all sides. Minimum air clearances must be met to assure adequate air flow for optimum performance.

Continuing research results in steady improvements; therefore, these specifications are subject to change without notice.



Taylor Company,
A Division of Carrier Commercial Refrigeration, Inc.
Rockton, Illinois 61072
815-624-8333 800-255-0626 Fax 815-624-8000
www.taylor-company.com

Printed in U.S.A.

051275-ADV 3/05